

**REQUEST FOR QUOTATION**

RFQ NO. 2022 - 10 - 02 - 0181  
DATE: 25-Oct-2022

COMPANY NAME  
COMPANY ADDRESS  
CONTACT PERSON  
CONTACT NO.  
COMPANY TIN

BDSK-101-10-622  
**POSTED**  
GEPS REF. No. \_\_\_\_\_  
DATE: 10/26/22

Sir/Madam:

Please quote your government price/s including delivery charges, VAT or other applicable taxes, and other incidental expenses for the goods listed in **Annex A**. Failure to indicate **TECHNICAL SPECIFICATIONS** could be basis for non-compliance. Also, furnish us with the descriptive brochures, catalogues, literatures and/or samples, if applicable.

If you are the exclusive manufacturer, distributor or agent in the Philippines for the goods listed in Annex A please attach in your quotation a duly notarized certification to this effect.

Please submit this form together with Annex A to **DSWD FO IX BAC OFFICE** on or before

Nov. 07, 2022 @ 5:00 PM.

Very truly yours,

**RENATO G. FOJAS**  
Regional Procurement Officer

Terms and Conditions:

- PURPOSE** : Repair and Maintenance of Outdoor Comfort Rooms
- PR NUMBER** : **2022 - 10 - 02 - 0181**
1. Award shall be made on per :  Item Basis  Lot Basis
2. Quotation validity : 30 CALENDAR DAYS FROM BID OPENING
3. Goods shall be delivered on : **15 DAYS AFTER RECEIPT OF PO**
4. Delivery Area : **BDSK, POLANCO, ZAMBOANGA DEL NORTE**
5. Terms of payment : W/ IN 60 CALENDAR DAYS AFTER DELIVERY
6. Liquidated Damages/Penalty : 1/10 of 1% of undelivered portion x No. of days of delay
7. In case of discrepancy between unit cost and total cost, unit cost shall prevail.
8. Warranty : N/A
9. Performance Security : N/A
10. Prospective supplier must be registered at the Philippine Government Electronic Procurement System (PhilGEPS). You may visit Philgeps website at [www.philgeps.gov.ph](http://www.philgeps.gov.ph) and register for free.

**REQUIRED:**

- Business/Mayor's Permit CY 2022**  
**Income / Business Tax Return For ABCs above P500K**  
**Omnibus Sworn Statement For ABCs above P500K**

(signature over printed name)

Supplier

PHILGEPS NO.: \_\_\_\_\_  
PHILGEPS EXPIRY: \_\_\_\_\_



SMALL VALUE PROCUREMENT

DSWD FIELD OFFICE IX  
1990-09-01 REV 01/13 OCT 2011

COMPANY NAME  
COMPANY ADDRESS  
CONTACT PERSON  
CONTACT NO.

DEPARTMENT OF SOCIAL WELFARE AND DEVELOPMENT  
GENERAL VICENTE ALVAREZ ST., ZAMBOANGA CITY  
JOHN MATHEW L. AREVALO  
917486475

ANNEX A: RFQ  
RFQ NO.  
DATE

2022-10-02-0181  
2022-10-20

ITEM NO.	QTY.	UNIT	PURCHASER'S SPECIFICATIONS	TOTAL ABC	BIDDER'S SPECIFICATIONS	UNIT COST	TOTAL COST
1	1	LGT	REPAIR AND MAINTAINANCE OF OUTDOOR COMFORT ROOM				
			SCOPE OF WORK				
	11.40	sq.m.	SITE WORKS				
	80.00	bd.ft.	SCAFFOLDINGS				
	9.36	sq.m.	CARPENTRY WORKS				
	128.62	kgs.	METAL WORKS				
	1.00	sq.m.	ROOFING WORKS				
	124.44	sq.m.	PAINTING WORKS				
	3.00	lots	INSTALLATION OF FIXTURES & ACCESSORIES				
	1.00	days	CONSTRUCTION FOREMAN				
	A		TOTAL DIRECT COST (MATERIALS, LABOR AND EQUIPMENT)	161,820.75			
	B		OCM (15% OF A)				
	C		CONTRACTOR'S PROFIT (10% OF A)				
	D		VAT (5% OF A + B + C)				
			XXXXXXXXXXXXXXXXX NOTHING FOLLOWS XXXXXXXXXXXXXXXXXXXXXXXXXXXX				

PURPOSE: Repair and Maintenance of Outdoor Comfort Rooms  
PR. NO.: 2022 - 10 - 02 - 0181

(SIGNATURE OVER PRINTED NAME)  
SUPPLIER

JOHN MATHEW L. AREVALO /  
CANNASSER

**REPUBLIC OF THE PHILIPPINES**  
**DEPARTMENT OF SOCIAL WELFARE AND DEVELOPMENT**  
**GEN. VICENTE ALVAREZ STREET, ZAMBOANGA CITY**

**PLANS**

**FOR THE PROPOSED REPAIR OF**  
**OUTDOOR COMFORT ROOMS**  
**ANASTACIO POLANCO, ZAMBOANGA DEL NORTE**

PROJECT NAME:  
**REPAIR OF OUTDOOR COMFORT ROOMS**

LOCATION:  
**BALAY DANGPAMAN SA KABATAAN (BO)  
ANASTACIO POLANCO, ZAMBOANGA DEL NORTE**

SHEET CONTENT:

**COVER SHEET**

APPROVED BY:   
**RIKURNI F. BANTAYAN, CE**  
Project Director  
 CONFIRMED BY:   
**MA SOCORRO S. MACOS, SMOV**  
PSO CHM

SUBMITTED BY:  
**EDEN M. OZAMPA, PSW**  
ONC BSOV/Project Field

CHECKER BY:   
**ROLISTE C. PALIS, CE**  
ADV. Engr. Civil Engr.

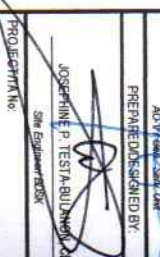
PREPARED/DESIGNED BY:  
  
**JOSEPHINE P. TESTA, BLDG/ENGR. CE**  
Civil Engineering

DATE SUBMITTED:

DRAWING STATUS:

DATE DESCRIPTION/REMARKS

PLAN CATEGORY	SHEET NUMBER	PAPER
CS-01	01/07	LOM



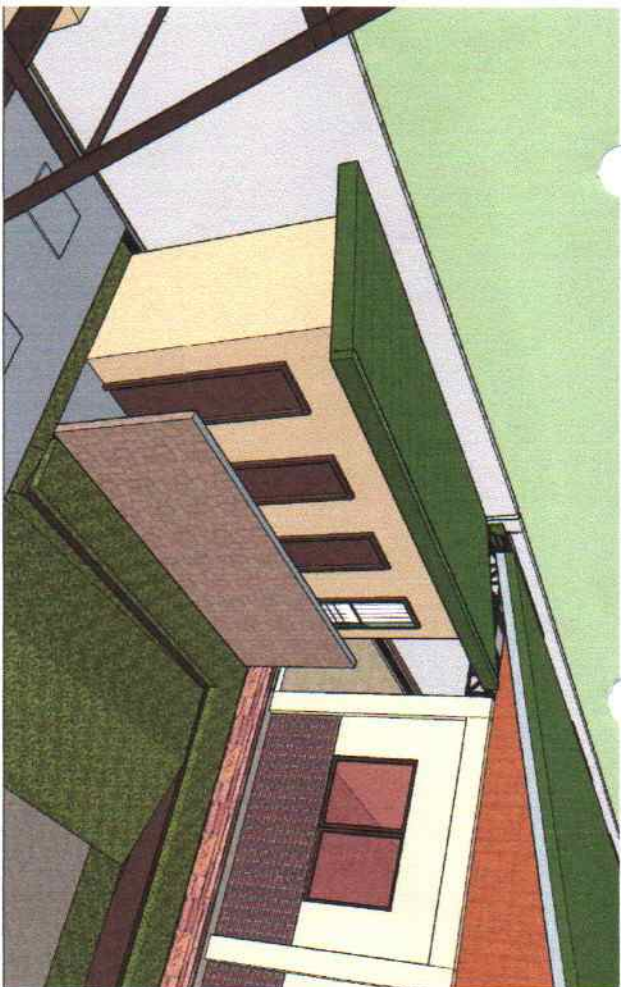

P E R S P E C T I V E

TABLE OF CONTENTS

CS-01	COVER SHEET
AR-01	PERSPECTIVE SITE DEVELOPMENT PLAN VICINITY PLAN
AR-02	FLOOR PLAN ROOF PLAN CEILING PLAN DOOR & WINDOW DETAILS AIR VENTILATION DETAIL SCHEDULE OF CEILING
AR-03	FRONT VIEW REAR VIEW RIGHT SIDE ELEVATION LEFT SIDE ELEVATION TRANSVERSE SECTION LONGITUDINAL SECTION
ST-01	ROOF FRAMING PLAN TRUSS DETAILS FASCIA FRAME DETAILS
EL-01	ELECTRICAL PLAN
PL-01	PLUMBING PLAN

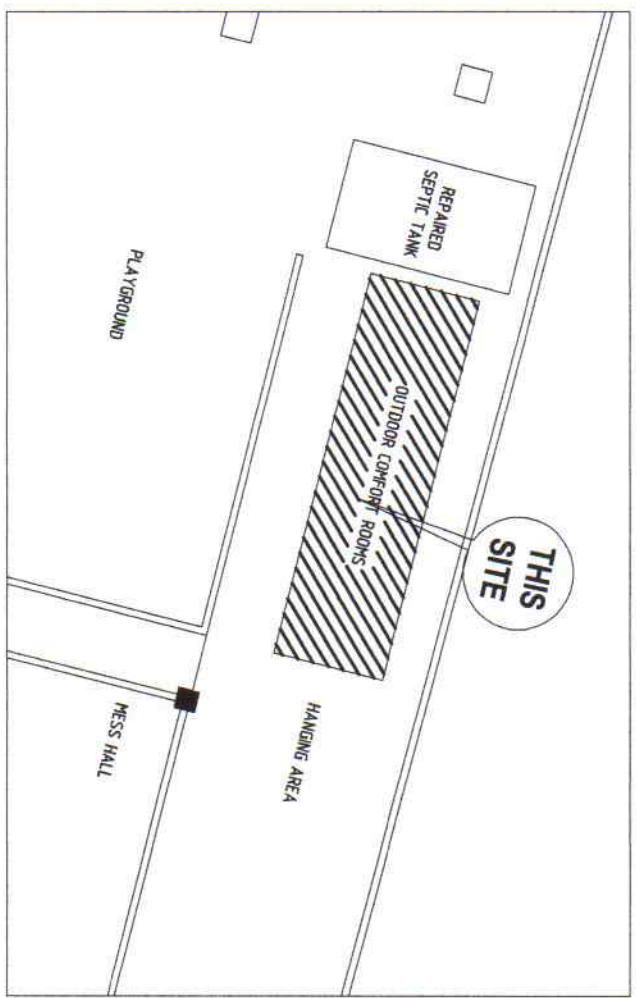

SITE DEVELOPMENT PLAN  
SCALE 1:100M

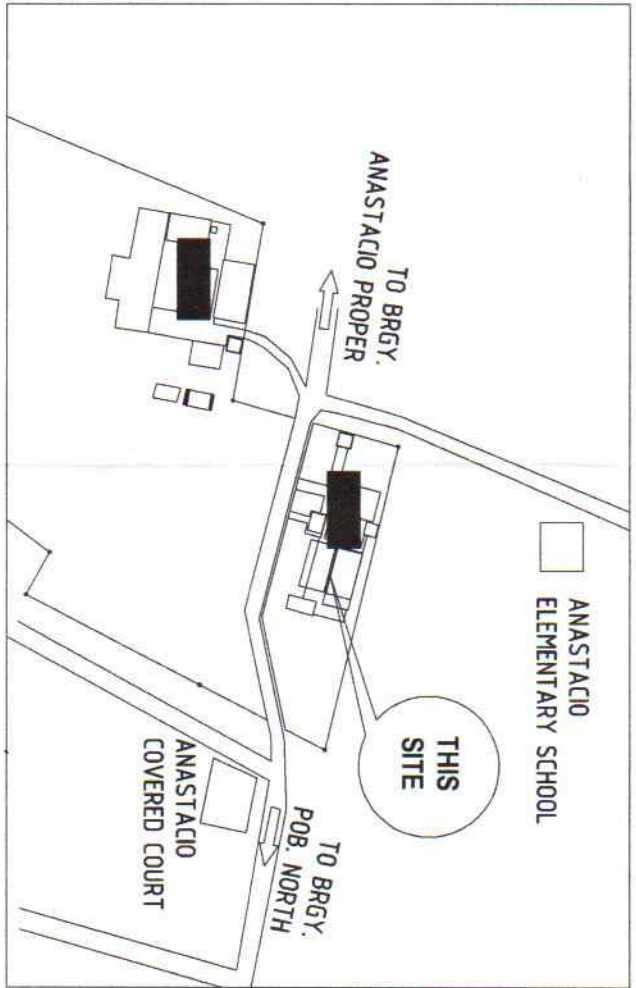

VICINITY PLAN  
SCALE NDS



Department of Social Welfare and Administration  
ADMINISTRATIVE FIELD OFFICE

PROJECT NAME:  
REPAIR OF OUT

LOCATION:  
BALAY DANGPANA  
ANASTACIO POLANG

SHEET CONTENT:  
TABLE CONTENT:  
PER SITE DE  
WCH

APPR  
RUDYNN T. EN  
NON

MA. SOCORR  
P

EBEN M. L.  
OIC BRK C

ROLFIN S.  
ADV. A

JOSEPHINE P.  
OIC BR

PROJECT NAME

DATE SUBMITTED

DATE

DESCRIPTION

PLAN CATEGORY

AR-01

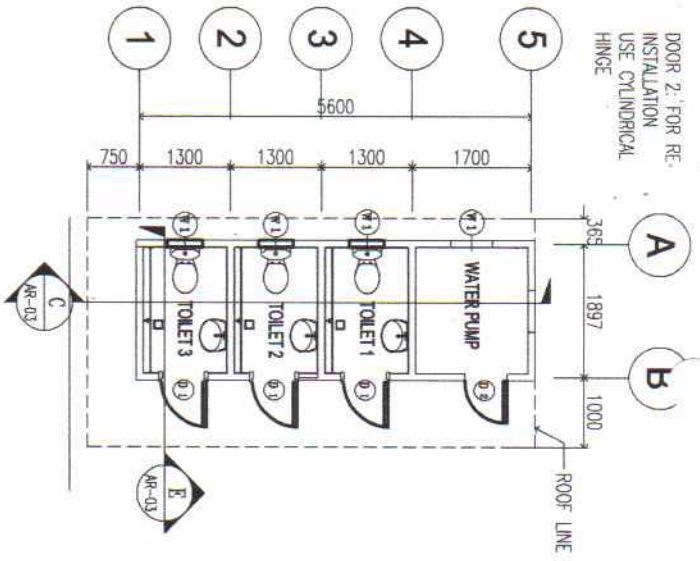

**A FLOOR PLAN**  
AR-02 SCALE 1:100M

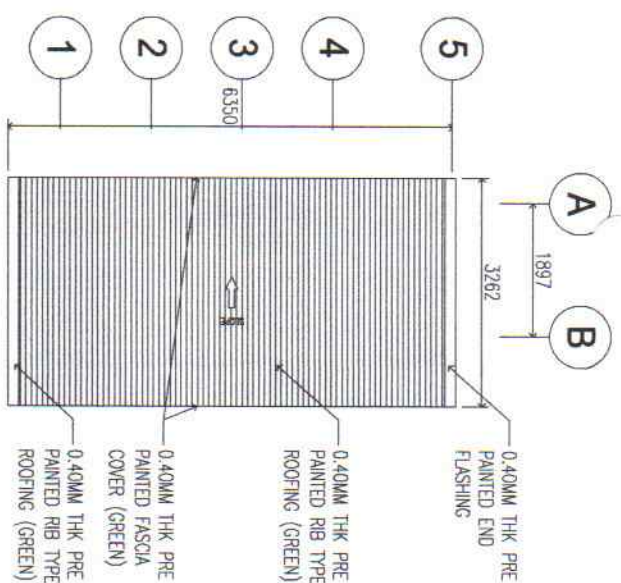

**B ROOF PLAN**  
AR-02 SCALE 1:100M

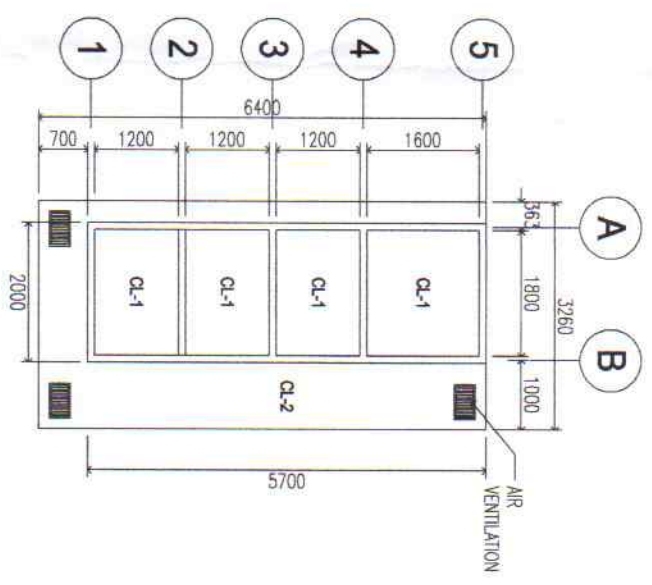

**C CEILING PLAN**  
AR-02 SCALE 1:100M

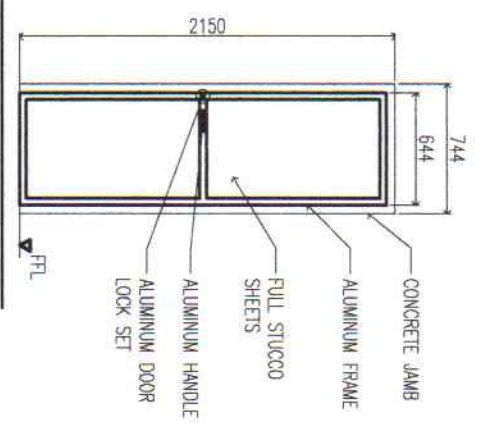

**D DOOR-1 DETAILS**  
AR-02 SCALE 1:100M

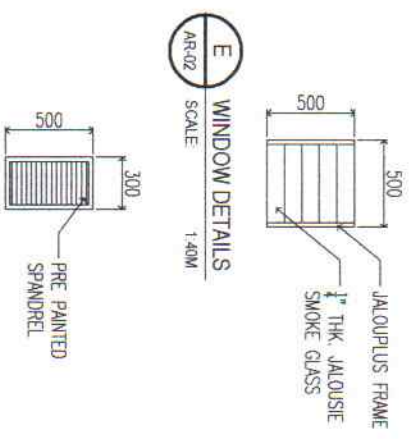

**E WINDOW DETAILS**  
AR-02 SCALE 1:40M

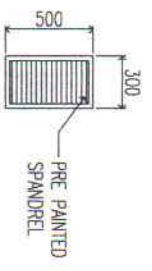

**F VENTILATION DETAILS**  
AR-02 SCALE 1:40M

MARKS	DESCRIPTION	REMARKS
CL-01	1/4 THK. HARDI-FLUX ELEV 2.50M	PROVIDE 12 mm X 38 mm X 5 m. X 0.8 mm THK. METAL CARRIING CHANNEL (CEILING JOIST) AT 1200 mm ON CENTER WITH 19 mm X 50 mm X 5 m. X 0.5 mm THK. METAL DOUBLE FURRING CHANNEL (CEILING HANGER) AT 400 mm ON CENTER AND WITH 12 mm X 38 mm X 5 m. X 0.8 mm THK. METAL CHANNEL (CEILING HANGERS) AT 1200 mm ON CENTER (TYPICAL ON ALL ROOMS)
CL-02	0.40MM PREPAINTED SPANDREL	PREPAINTED COLOR (CREAM) OR THE LIKE ON A PRE PAINTED WALL ANGLE

**G SCHEDULE OF CEILING**  
AR-02 SCALE NOS

Department of Social Administration  
PROJECT NAME: REPAIR OF OUTD  
LOCATION: BALAY DANGPAPAN, ANASTACIA POLAN  
SHEET CONTENT: FLOOR PL, CEILING PLAN, WINDOW AND SCHEDULE

DATE SUBMITTED: \_\_\_\_\_  
DRAWN: \_\_\_\_\_  
CHECKED: \_\_\_\_\_  
APPROVED: \_\_\_\_\_  
PROJECT CHARGE: \_\_\_\_\_  
DATE: \_\_\_\_\_

MA. SOCORRO  
EDEN M. \_\_\_\_\_  
SUB: \_\_\_\_\_

AR-02



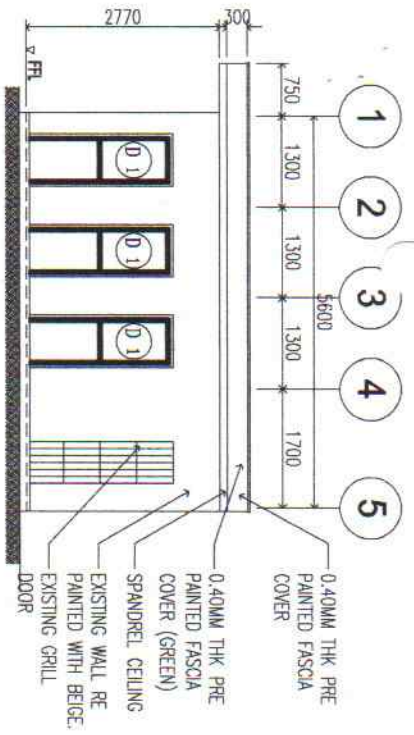

**A FRONT VIEW**  
AR-03 SCALE: 1:100M

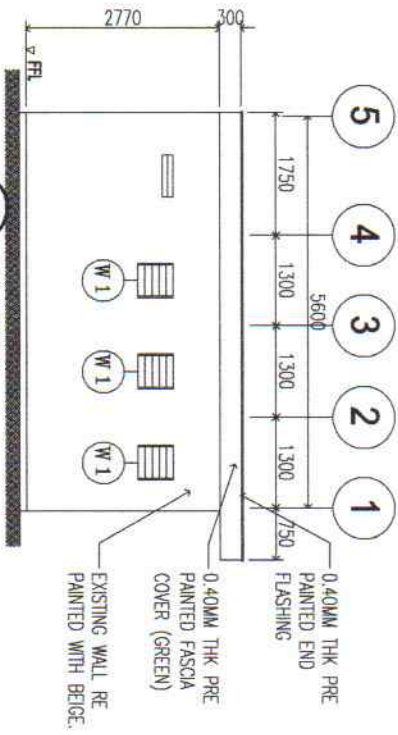

**B REAR VIEW**  
AR-03 SCALE: 1:100M

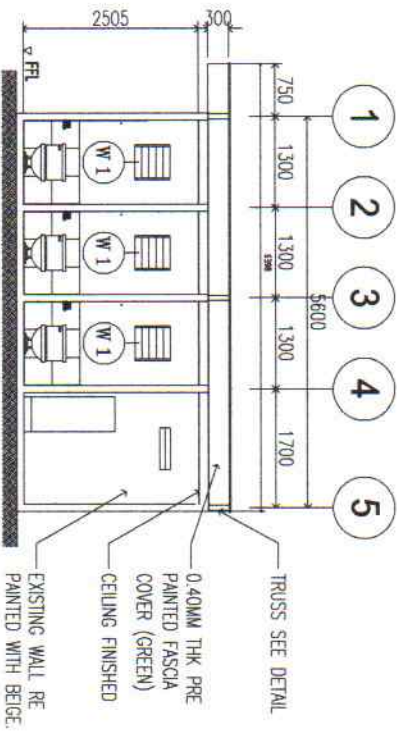

**C LONGITUDINAL SECTION**  
AR-03 SCALE: 1:100M

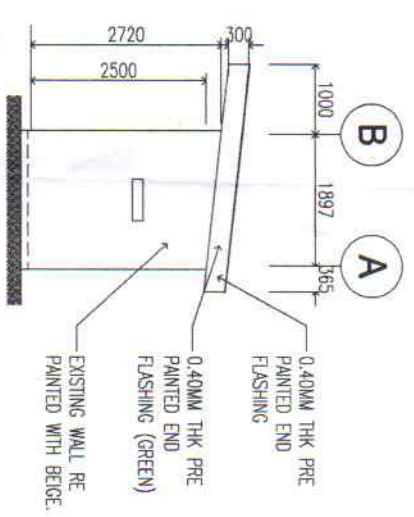

**D RIGHT SIDE ELEVATION**  
AR-03 SCALE: 1:100M

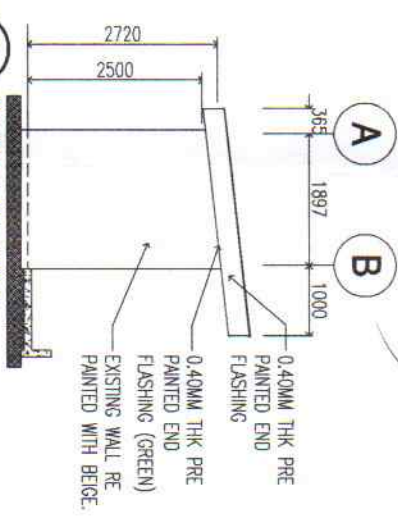

**E LEFT SIDE ELEVATION**  
AR-03 SCALE: 1:100M

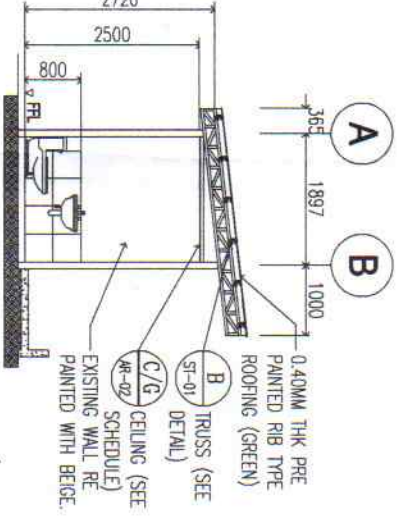

**F TRANSVERSE SECTION**  
AR-03 SCALE: 1:100M



Department of Social Welfare and Administration

PROJECT NAME: REPAIR OF QUITY

LOCATION: BALAY DANGPANA, ANAYDAO, POLAND

SHEET CONTENT: FRONT AND REAR VIEW, LONGITUDINAL AND TRANSVERSE SECTION

DATE: \_\_\_\_\_  
DRAWN BY: \_\_\_\_\_  
CHECKED BY: \_\_\_\_\_  
APPROVED BY: \_\_\_\_\_  
PROJECT NO: \_\_\_\_\_  
SHEET NO: \_\_\_\_\_

DATE	DESCRIPTION	DRAWN





Department of Social Welfare and Administration

PROJECT NAME: REPAIR OF OUTLET

LOCATION: BALAY DANGPANA, AMSTICO, POLANG

SHEET CONTENT: ELECT

APPROVED: [Signature]

MA. SOCORR

SUBJ: [Blank]

DESIGNER: [Signature]

DATE: [Blank]

DATE SUBMITTED: [Blank]

PROJECT No. [Blank]

DATE: [Blank]

DESCRIPTION: [Blank]

DATE: [Blank]

DATE: [Blank]

DATE: [Blank]

DATE: [Blank]

DATE: [Blank]

DATE: [Blank]

DATE: [Blank]

DATE: [Blank]

DATE: [Blank]

DATE: [Blank]

DATE: [Blank]

DATE: [Blank]

DATE: [Blank]

DATE: [Blank]

DATE: [Blank]

DATE: [Blank]

DATE: [Blank]

DATE: [Blank]

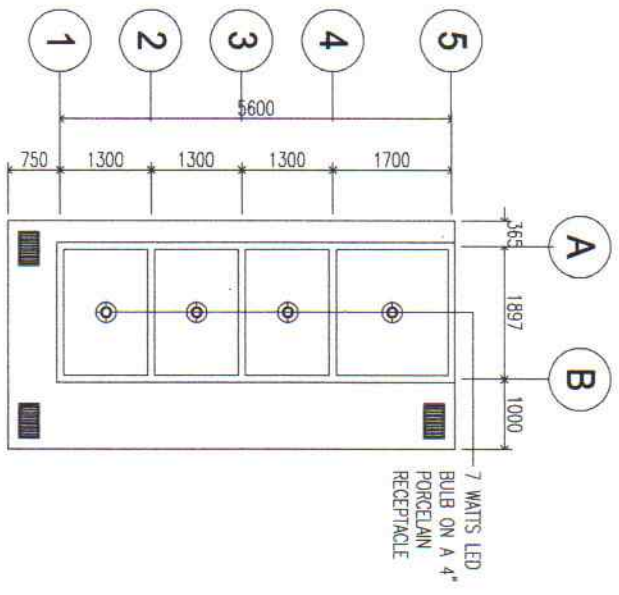

FIXTURES FOR REMOVAL AND TO BE REPLACED:  
 4-PORCELAIN RECEPTACLE  
 4-7 WATTS LED BULB

**A** ELECTRICAL PLAN  
 EL-01 SCALE: 1:100M



